

## Standard Specifications Roll and Cut Groove for Steel Pipe

### General Description

Grooved pipes and fittings provide an economical and efficient method of joining pipe in fire protection systems.

The grooved piping system joins together two pipe ends by using a coupling that is seated in grooves at the end of each pipe. When the coupling is assembled, the coupling keys engage the grooves around the circumference of both pipes, providing a secure connection.

There are two types of grooving: roll grooving and cut grooving. Roll grooving uses a special machine that rotates the end of a pipe through a roll set, displacing the metal and forming a groove on the outside surface of the pipe. Roll grooving is limited to use with pipe having a hardness value of HB180 or less. Roll grooving can be accomplished on carbon steel, stainless steel, copper, and aluminum. However, care must be taken to use the proper equipment and roll sets (which may vary with piping material) to create the groove. Consult the grooving machine manual or roll set instructions for further information. If necessary, contact Tyco Fire Protection Products (TFPP) for assistance.

Cut grooving is performed by turning the pipe on a lathe, removing metal from the outside surface of the pipe to create the groove. Cut grooving is intended to be used with Schedule 30 and heavier wall pipe. Refer to Figure 2, "T" Minimum Wall Inches (mm).

### Technical Data

- The maximum allowable tolerances for IPS Pipe from square cut ends are:
  - Sizes 1 to 3 (DN25 to DN80) = 0.030 inch (0,76 mm)
  - Sizes 4 to 6 (DN100 to DN150) = 0.045 inch (1,14 mm)
  - Sizes 8 to 12 (DN200 to DN300) = 0.060 inch (1,52 mm)
- Gasket Seating Surface "A" must be free from score marks, ridges, indentations, projections, loose paint, scale, dirt chips, grease, and rust that would prevent a positive seal.
- Groove Diameter "C" must be uniform depth around the circumference of the pipe.
- Groove Depth "D" is a reference dimension of the distance from the pipe outer surface to the groove bottom, with regards to groove concentricity about the pipe. This dimension is a reference only. The actual dimension "C" must be maintained.
- Minimum Wall Thickness "T" is the minimum wall thickness that should be roll or cut grooved.
- Maximum allowable pipe end flare diameter is measured at the pipe end diameter (roll grooved pipe only).

### Limited Warranty

For warranty terms and conditions, visit [www.tyco-fire.com](http://www.tyco-fire.com).

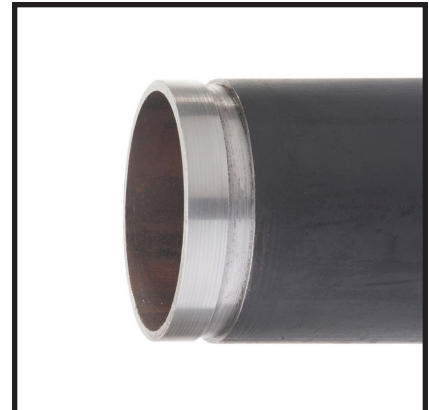

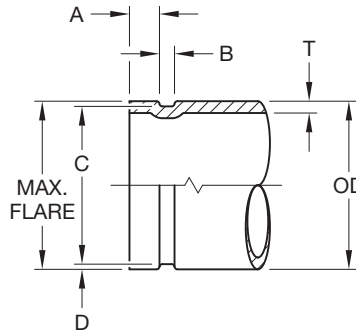

Nominal Pipe Size, ANSI Inches (DN)	Pipe O.D., Inches (mm)			A ±0.030 ±0,76 mm, Inches (mm)	B ±0.030 ±0,76 mm, Inches (mm)	C Groove Diameter, Inches (mm)		D Nominal Groove Depth, Inches (mm)	T Minimum Wall, Inches (mm)	Maximum Allowable Flare Diameter, Inches (mm)
	O.D., Inches (mm)	Tolerance				Actual	Tol. +0.000			
		+	-							
1 (25)	1.315 (33,7)	0.028 (0,71)	0.015 (0,38)	0.625 (15,88)	0.281 (7,14)	1.190 (30,23)	-0.015 (-0,38)	0.063 (1,60)	0.065 (1,65)	1.43 (36,32)
1-1/4 (32)	1.660 (42,4)	0.029 (0,74)	0.016 (0,41)	0.625 (15,88)	0.281 (7,14)	1.535 (38,99)	-0.015 (-0,38)	0.063 (1,60)	0.065 (1,65)	1.77 (44,96)
1-1/2 (40)	1.900 (48,3)	0.019 (0,48)	0.019 (0,48)	0.625 (15,88)	0.281 (7,14)	1.775 (45,09)	-0.015 (-0,38)	0.063 (1,60)	0.065 (1,65)	2.01 (51,05)
2 (50)	2.375 (60,3)	0.024 (0,61)	0.024 (0,61)	0.625 (15,88)	0.344 (8,74)	2.250 (57,15)	-0.015 (-0,38)	0.063 (1,60)	0.065 (1,65)	2.48 (62,99)
2-1/2 (65)	2.875 (73,0)	0.029 (0,74)	0.029 (0,74)	0.625 (15,88)	0.344 (8,74)	2.720 (69,09)	-0.018 (-0,46)	0.078 (1,98)	0.083 (2,11)	2.98 (75,69)
76,1 (65)	3.000 (76,2)	0.030 (0,76)	0.030 (0,76)	0.625 (15,88)	0.344 (8,74)	2.845 (72,26)	-0.018 (-0,46)	0.076 (1,93)	0.083 (2,11)	3.10 (78,74)
3 (80)	3.500 (88,9)	0.035 (0,89)	0.031 (0,79)	0.625 (15,88)	0.344 (8,74)	3.344 (84,94)	-0.018 (-0,46)	0.078 (1,98)	0.083 (2,11)	3.60 (91,44)
108,0 (100)	4.250 (108,0)	0.043 (1,09)	0.031 (0,79)	0.625 (15,88)	0.344 (8,74)	4.084 (103,73)	-0.020 (-0,51)	0.083 (2,11)	0.083 (2,11)	4.35 (110,49)
4 (100)	4.500 (114,3)	0.045 (1,14)	0.031 (0,79)	0.625 (15,88)	0.344 (8,74)	4.334 (110,08)	-0.020 (-0,51)	0.083 (2,11)	0.083 (2,11)	4.60 (116,84)
133,4 (125)	5.250 (133,4)	0.053 (1,35)	0.031 (0,79)	0.625 (15,88)	0.344 (8,74)	5.084 (129,13)	-0.022 (-0,56)	0.083 (2,11)	0.109 (2,77)	5.35 (135,89)
139,7 (125)	5.500 (139,7)	0.056 (1,42)	0.031 (0,79)	0.625 (15,88)	0.344 (8,74)	5.334 (135,48)	-0.022 (-0,56)	0.083 (2,11)	0.109 (2,77)	5.60 (142,24)
5 (125)	5.563 (141,3)	0.056 (1,42)	0.031 (0,79)	0.625 (15,88)	0.344 (8,74)	5.395 (137,03)	-0.022 (-0,56)	0.084 (2,13)	0.109 (2,77)	5.66 (143,76)
159,0 (150)	6.250 (159,0)	0.063 (1,60)	0.031 (0,79)	0.625 (15,88)	0.344 (8,74)	6.084 (154,53)	-0.030 (-0,76)	0.083 (2,11)	0.109 (2,77)	6.35 (161,29)
165,1 (150)	6.500 (165,1)	0.063 (1,60)	0.031 (0,79)	0.625 (15,88)	0.344 (8,74)	6.330 (160,78)	-0.022 (-0,56)	0.085 (2,16)	0.109 (2,77)	6.60 (167,64)
6 (150)	6.625 (168,3)	0.063 (1,60)	0.031 (0,79)	0.625 (15,88)	0.344 (8,74)	6.455 (163,96)	-0.022 (-0,56)	0.085 (2,16)	0.109 (2,77)	6.73 (170,94)
216,3 (200)	8.516 (216,3)	0.063 (1,60)	0.031 (0,79)	0.750 (19,05)	0.469 (11,91)	8.331 (211,61)	-0.025 (-0,64)	0.092 (2,34)	0.109 (2,77)	8.69 (220,73)
8 (200)	8.625 (219,1)	0.063 (1,60)	0.031 (0,79)	0.750 (19,05)	0.469 (11,91)	8.441 (214,40)	-0.025 (-0,64)	0.092 (2,34)	0.109 (2,77)	8.80 (223,52)
10 (250)	10.750 (273,1)	0.063 (1,60)	0.031 (0,79)	0.750 (19,05)	0.469 (11,91)	10.562 (268,27)	-0.027 (-0,69)	0.094 (2,39)	0.134 (3,40)	10.92 (277,37)
12 (300)	12.750 (323,9)	0.063 (1,60)	0.031 (0,79)	0.750 (19,05)	0.469 (11,91)	12.531 (318,29)	-0.030 (-0,76)	0.109 (2,77)	0.156 (3,96)	12.92 (328,17)

**FIGURE 1**  
**STANDARD ROLL GROOVE**  
**STEEL PIPE SPECIFICATIONS**

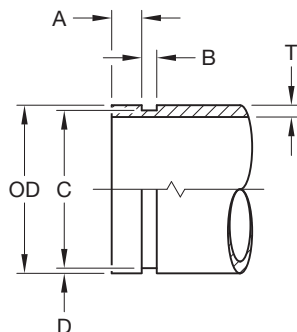

Nominal Pipe Size, ANSI Inches (DN)	Pipe O.D., Inches (mm)		A ±0.030 ±0,76 mm, Inches (mm)	B ±0.030 ±0,76 mm, Inches (mm)	C Groove Diameter, Inches (mm)		D Nominal Groove Depth, Inches (mm)	T Minimum Wall, Inches (mm)	
	O.D., Inches (mm)	Tolerance			Actual	Tol. +0.000			
		+							-
1 (25)	1.315 (33,7)	0.028 (0,71)	0.015 (0,38)	0.625 (15,88)	0.313 (7,95)	1.190 (30,23)	-0.015 (-0,38)	0.063 (1,60)	0.133 (3,38)
1-1/4 (32)	1.660 (42,4)	0.029 (0,74)	0.016 (0,41)	0.625 (15,88)	0.313 (7,95)	1.535 (38,99)	-0.015 (-0,38)	0.063 (1,60)	0.140 (3,56)
1-1/2 (40)	1.900 (48,3)	0.019 (0,48)	0.019 (0,48)	0.625 (15,88)	0.313 (7,95)	1.775 (45,09)	-0.015 (-0,38)	0.063 (1,60)	0.145 (3,68)
2 (50)	2.375 (60,3)	0.024 (0,61)	0.024 (0,61)	0.625 (15,88)	0.313 (7,95)	2.250 (57,15)	-0.015 (-0,38)	0.063 (1,60)	0.154 (3,91)
2-1/2 (65)	2.875 (73,0)	0.029 (0,74)	0.029 (0,74)	0.625 (15,88)	0.313 (7,95)	2.720 (69,09)	-0.018 (-0,46)	0.078 (1,98)	0.188 (4,78)
76,1 (65)	3.000 (76,2)	0.030 (0,76)	0.030 (0,76)	0.625 (15,88)	0.313 (7,95)	2.845 (72,26)	-0.018 (-0,46)	0.076 (1,93)	0.188 (4,78)
3 (80)	3.500 (88,9)	0.035 (0,89)	0.031 (0,79)	0.625 (15,88)	0.313 (7,95)	3.344 (84,94)	-0.018 (-0,46)	0.078 (1,98)	0.188 (4,78)
108,0 (100)	4.250 (108,0)	0.042 (1,07)	0.031 (0,79)	0.625 (15,88)	0.375 (9,53)	4.084 (103,73)	-0.020 (-0,51)	0.083 (2,11)	0.203 (5,16)
4 (100)	4.500 (114,3)	0.045 (1,14)	0.031 (0,79)	0.625 (15,88)	0.375 (9,53)	4.334 (110,08)	-0.020 (-0,51)	0.083 (2,11)	0.203 (5,16)
133,4 (125)	5.250 (133,4)	0.052 (1,32)	0.031 (0,79)	0.625 (15,88)	0.375 (9,53)	5.084 (129,13)	-0.020 (-0,51)	0.083 (2,11)	0.203 (5,16)
139,7 (125)	5.500 (139,7)	0.056 (1,42)	0.031 (0,79)	0.625 (15,88)	0.375 (9,53)	5.334 (135,48)	-0.022 (-0,56)	0.083 (2,11)	0.203 (5,16)
5 (125)	5.563 (141,3)	0.056 (1,42)	0.031 (0,79)	0.625 (15,88)	0.375 (9,53)	5.395 (137,03)	-0.022 (-0,56)	0.084 (2,13)	0.203 (5,16)
159,0 (150)	6.250 (158,8)	0.063 (1,60)	0.031 (0,79)	0.625 (15,88)	0.375 (9,53)	6.084 (154,53)	-0.022 (-0,56)	0.083 (2,11)	0.219 (5,56)
165,1 (150)	6.500 (165,1)	0.063 (1,60)	0.031 (0,79)	0.625 (15,88)	0.375 (9,53)	6.330 (160,78)	-0.022 (-0,56)	0.085 (2,16)	0.219 (5,56)
6 (150)	6.625 (168,3)	0.063 (1,60)	0.031 (0,79)	0.625 (15,88)	0.375 (9,53)	6.455 (163,96)	-0.022 (-0,56)	0.085 (2,16)	0.219 (5,56)
216,3 (200)	8.516 (216,3)	0.063 (1,60)	0.031 (0,79)	0.750 (19,05)	0.438 (11,13)	8.331 (211,61)	-0.025 (-0,64)	0.092 (2,34)	0.238 (6,05)
8 (200)	8.625 (219,1)	0.063 (1,60)	0.031 (0,79)	0.750 (19,05)	0.438 (11,13)	8.441 (214,40)	-0.025 (-0,64)	0.092 (2,34)	0.238 (6,05)
10 (250)	10.750 (273,1)	0.063 (1,60)	0.031 (0,79)	0.750 (19,05)	0.500 (12,70)	10.562 (268,27)	-0.027 (-0,69)	0.094 (2,39)	0.250 (6,35)
12 (300)	12.750 (323,9)	0.063 (1,60)	0.031 (0,79)	0.750 (19,05)	0.500 (12,70)	12.531 (318,29)	-0.030 (-0,76)	0.109 (2,77)	0.279 (7,09)

**FIGURE 2  
STANDARD CUT GROOVE  
STEEL PIPE SPECIFICATIONS**

