

Model WMA-1 Water Motor Alarm Hydraulically Operated Mechanical Sprinkler Alarm

General Description

The TYCO Model WMA-1 Water Motor Alarm is a hydraulically operated outdoor alarm designed for use with fire protection system waterflow detection valves. It is lightweight yet rugged, and it can be used in conjunction with alarm check, dry pipe, deluge, and pre-action valves to sound a local alarm.

The Water Motor Alarm is suitable for mounting to any type of rigid wall and can accommodate a wall thickness range of 2 to 18 in. (50 to 450 mm). It is provided with a listed and approved TYCO Model WMA-1 Y-Strainer for use in the alarm line.

The Model WMA-1 utilizes a lightweight, impeller design that can produce a very high sound pressure level. The Gong, Gong Mount, and Water Motor Housing are fabricated from corrosion-resistant aluminum alloys. The polymer drive bearings do not require lubrication, and the Gong is closely fitted to the Gong Mount to eliminate the need for a separate cover.

The Model WMA-1 Water Motor Alarm is a re-designation for the Central Model F-2, Gem Model F630, and Star Model S450.

NOTICE

The TYCO Model WMA-1 Water Motor Alarm described herein must be installed and maintained in compliance with this document, as well as with the applicable standards of the National Fire Protection Association (NFPA), in addition to the standards of any authorities having jurisdiction. Failure to do so may impair the performance of this device.

The owner is responsible for maintaining their fire protection system and devices in proper operating condition. Contact the installing contractor or product manufacturer with any questions.

Technical Data

Approvals

UL and ULC Listed
FM, LPCB and VdS Approved

Gong Finish

Red or Aluminum

Working Water Pressure Range

7 to 300 psi (0,5 to 20,7 bar)

Nozzle K-factor

0.7 GPM/psi^{1/2} (10,1 LPM/bar^{1/2})

Y-Strainer

3/4 in., cast iron, 20 mesh screen

Trim Components

Galvanized steel nipples and cast iron fittings

Design Data

The TYCO Model WMA-1 Water Motor Alarm must be used in accordance with the following design criteria:

Item 1. The Y-Strainer is to be located at the alarm outlet of the waterflow detection valve trim.

Item 2. The Water Motor Alarm must only be mounted to a rigid wall surface that will not permit the Striker /Gong Mount to loosen and fall out of alignment.

Item 3. In order to obtain the highest possible sound level, the Water Motor Alarm should be located as close as possible to the waterflow detecting valve. For guidance, refer to NFPA 13.

Item 4. The alarm line piping from the alarm outlet of the waterflow detection valve trim to the Water Motor Alarm must be 3/4 in. (DN20) in size throughout and it must be galvanized steel, brass, or other suitable corrosion-resistant material.

Item 5. The alarm line piping must be positioned such that it can be drained back to the waterflow detection valve trim.

Item 6. The Clean-Out Sump Plug is to be located vertically below the Inlet to the Water Motor.



Item 7. Piping from the Water Motor Drain must be a minimum of 1 in. (DN25) in size throughout and directed to an open drain in order to ensure proper drainage for obtaining the maximum sound pressure level.

Note: *The Water Motor Alarm Drain may be connected to the main drain of a waterflow detection valve if a non-spring loaded swing-type check valve is installed in a horizontal portion of the water motor alarm drain piping (before its connection to the main drain).*

Item 8. In order to minimize any wall staining that can be created by drain water, it is recommended that the drain piping from the Water Motor be galvanized steel, brass, or other suitable corrosion-resistant material.

Item 9. Drain water must be directed to prevent accidental damage to property or danger to persons when the alarm is operating or thereafter.

Item 10. The alarm line drain, at the waterflow detection valve, must be maintained at a minimum temperature of 40°F (4°C).

NO.	DESCRIPTION	QTY.	REF.
1	Water Motor	1	92-630-1-012
2	Support Washer	1	NR
3	Drive Shaft Sleeve	1	NR
4	Drive Shaft	1	NR
5	Gong Mount	1	NR
6	Striker	1	See (a)
7	Gong	1	See (a)
8	Cap Nut	1	See (a)
(a)	Red Gong Repair Kit includes items:		
	6, 7 (red), and 8	1	92-630-1-025
(a)	Aluminum Gong Repair Kit includes items:		
	6, 7 (alum.), and 8	1	92-630-2-025

NR: Not Replaceable

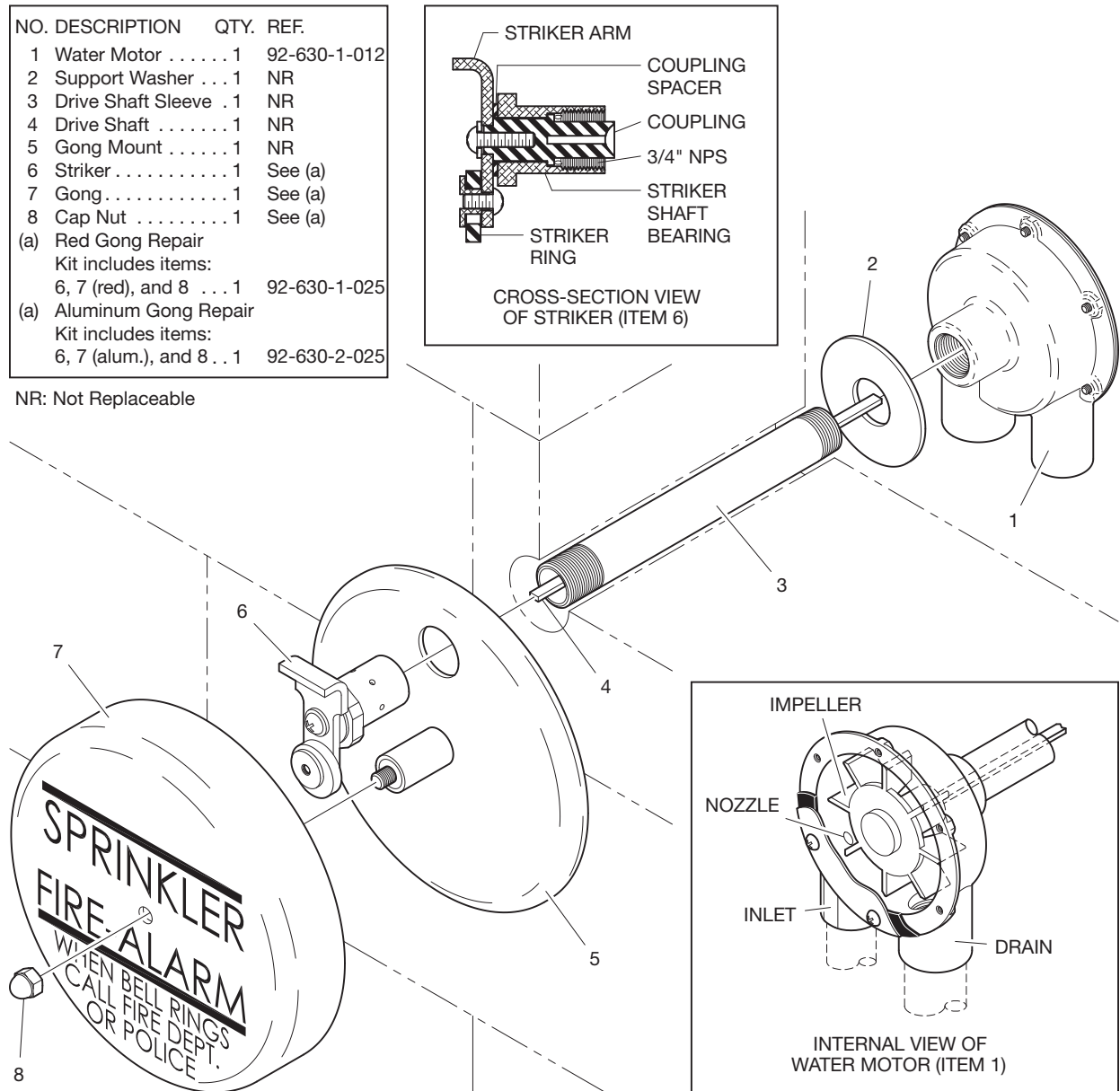

FIGURE 1
MODEL WMA-1 WATER MOTOR ALARM ASSEMBLY

Item 11. A single Water Motor Alarm may be connected to the alarm lines from a maximum of three separate fire protection systems. However, when two or three alarm lines are interconnected, each alarm line must be provided with the following:

- 3/4 in. Model WM-1 Y-Strainer (P/N 52-271-1001)
- 3/4 in. Check Valve with 3/32 inch orifice (P/N 52-403-1-005)

Strainers must be located at the alarm outlet in the trim of each of the waterflow detection valves. Check valves must be located between each strainer and the interconnection with the alarm line from another system.

Operation

Upon operation of the alarm check, dry pipe, deluge, or preaction valve to which the TYCO Model WMA-1 Water Motor Alarm is connected, water will flow to the Water Motor and through the Inlet Nozzle. As water flows through the Inlet Nozzle, a high velocity jet is formed that impinges on the Impeller, causing the Impeller and the Striker to rotate. With each rotation, the free swinging Striker Ring hits the Gong and sounds the alarm. The spent water is then drained through the 1 inch outlet.

The alarm will sound as long as water is flowing into the system and flowing

to the Water Motor Alarm. Water in the alarm line will automatically drain back through the orifice, which is also provided in the trim of the waterflow detection valve.

The Water Motor Alarm does not have to be reset after an operation. However, if the alarm was silenced during operation by closing an alarm control valve, the alarm control valve must be reopened after the fire protection system is restored to service.

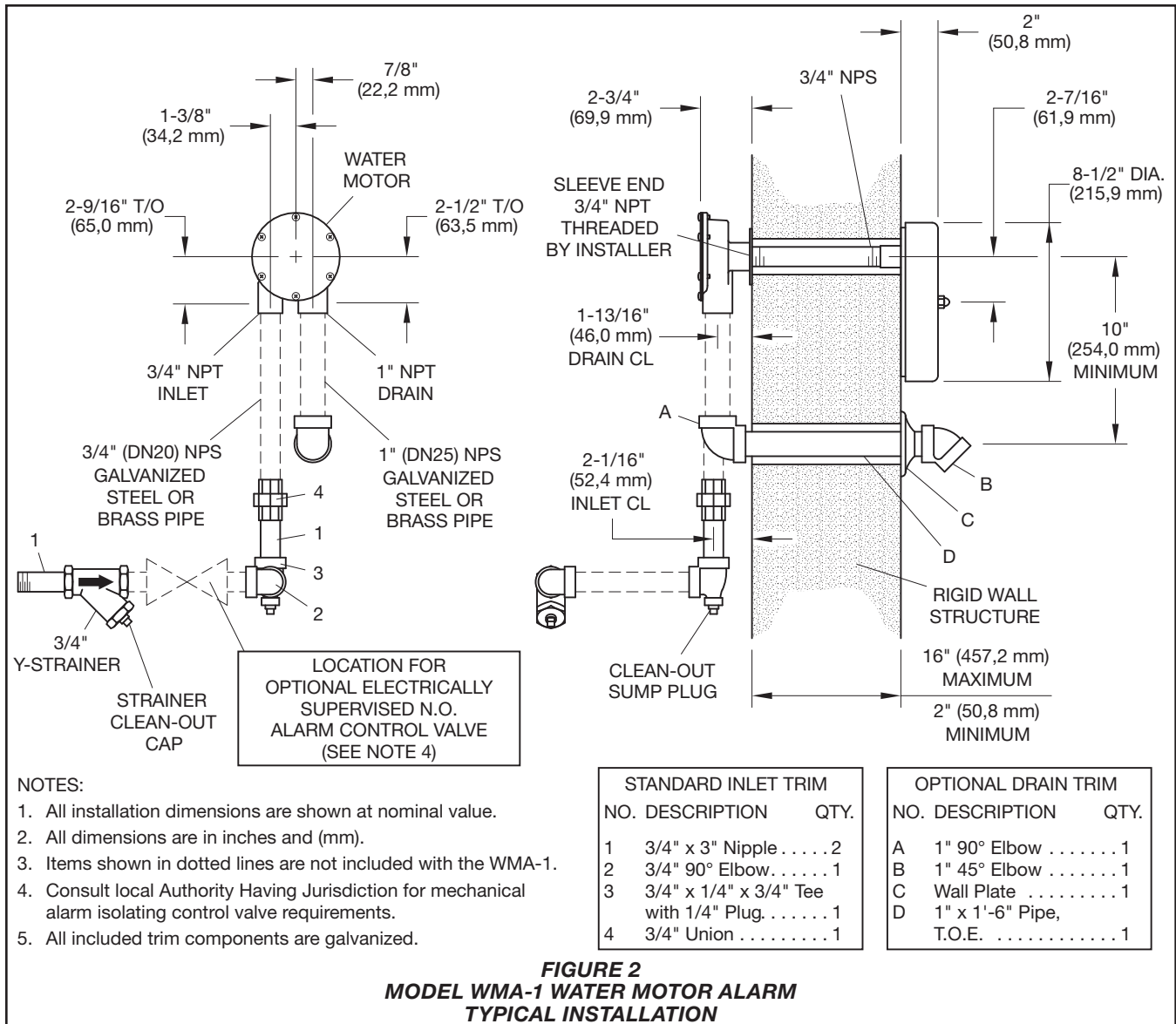

Installation

The TYCO Model WMA-1 Water Motor Alarm must be installed in accordance with this section.

Step 1. Mark the through-wall locations for the centerlines of the Sleeve and Drain Outlet. The Drain Outlet must be located at least 10 in. (250 mm) below the Sleeve per Figure 2.

Step 2. Make 1-1/2 in. (38 mm) diameter holes straight through the wall at both locations.

Step 3. Cut the non-threaded end of the Sleeve to a length equal to that of the wall thickness plus 0 to 1/8 in. (0 to 3 mm). Thread the cut end to 3/4 in. NPT per ANSI B1.20.1.

Step 4. Install the alarm line piping up to and including the Union half per Item 4, Figure 2.

Note: Use thread sealant sparingly on male threads only.

Step 5. Prior to initiating installation of the Water Motor Alarm, mount the Drain Trim (less the Wall Plate and 45° Elbow) as well as the balance of alarm line piping, including the other Union half, to the Water Motor.

Step 6. Tighten the NPT threaded end of the Sleeve into the Body, hand-tight plus 1/8 turn.

Step 7. Slip the Support Washer over the Sleeve and place the assembly in position against the wall.

Step 8. Tighten the 3/4 in. Union. Install the Wall Plate and tighten the 45° Elbow.

Note: Apply pressure against the outside edge of the Water Motor Body and verify that the Body and Support Washer sit squarely against the wall. If

not, adjust the alarm line and/or drain piping to suit.

Step 9. From the outside wall, insert the Drive Shaft through the Sleeve and fully insert it into the Impeller.

Note: When fully inserted, the Shaft should protrude beyond the face of the wall by approximately 20 minus 2 in. (508,0 minus 50,8 mm) wall thickness.

Mark the Drive Shaft at a point of approximately 1/8 to 1/4 in. (3,2 to 6,4 mm) inside the face of the wall. Remove the Shaft and cut it where previously marked. File off burrs from the cut end of the Drive Shaft. Re-insert the Drive Shaft through the Sleeve and fully insert it into the Impeller.

Step 10. Hold the Gong Mount in position against the wall, engage the Coupling with the Drive Shaft, and then carefully thread the Striker Shaft

Bearing onto the Sleeve. Securely tighten the Striker Shaft Bearing using a pair of tongue-and-groove pliers on the 1-1/2 in. (38 mm) hex end.

Step 11. Spin the Striker by hand and verify that it spins freely, without any sign of binding. If it does not, make the necessary adjustments.

Step 12. Install the Gong and securely tighten the Cap Nut. The identification sign lettering must be orientated horizontally.

Step 13. Test the Water Motor Alarm by opening the alarm test valve in the trim of the waterflow detection valve. The alarm must be clear and steady. If it is not, make the necessary adjustments.

NOTICE

Testing of the Water Motor Alarm may result in operation of other associated alarms. Consequently, notification must be given to the owner and the fire department, central control station, or other signal station to which the alarms are connected.

Care and Maintenance

The TYCO Model WMA-1 Water Motor Alarm must be maintained and serviced in accordance with this section.

Before closing a fire protection system main control valve for maintenance work on the fire protection system that it controls, obtain permission to shut down the affected fire protection system from the proper authorities and notify all personnel who may be affected by this decision.

Testing of the Water Motor Alarm may result in operation of other associated alarms. Consequently, notification must be given to the owner and the fire department, central control station, or other signal station to which the alarms are connected.

If the alarm was silenced during operation, the alarm control valve must be reopened immediately after the fire protection system is restored to service.

The owner is responsible for the inspection, testing, and maintenance of their fire protection system and devices in compliance with this document, as well as with the applicable standards of the National Fire Protection Association (e.g., NFPA 25), in addition to the standards of any other authorities having jurisdiction. Contact the installing contractor or product manufacturer regarding any questions.

Automatic sprinkler systems are recommended to be inspected, tested, and maintained by a qualified Inspection Service in accordance with local requirements and/or national codes.

The following procedures and inspections should be performed as indicated, in addition to any specific requirements of the NFPA, and any impairment must be immediately corrected:

Step 1. The Model WMA-1 Water Motor Alarm does not require any regularly scheduled maintenance. Rotating parts do not require lubrication. It is recommended, however, that fire alarms be periodically operated (inspected) to verify that they generate a clear and steady sound. Correct any impairment immediately.

Step 2. The inspection should be made quarterly or more frequently, as may be necessary for locations subject to vandalism.

The Y-Strainer and Sump are to be cleaned out after each operation of the Water Motor Alarm and after the alarm line piping has been drained.

NOTICE

With reference to Figure 2, in the event of a WMA-1 malfunction, inspect and clean the Y-Strainer of obstruction prior to removing the Water Motor.

Make no attempt to disassemble, repair, or internally clean the Water Motor. The Water Motor is not a field serviceable part and must be replaced if malfunction is determined.

Limited Warranty

For warranty terms and conditions, visit www.tyco-fire.com.

Ordering Procedure

Orders for the WMA-1 Water Motor Alarm Assembly, Optional Drain Trim, and replacement parts must include the description and Part Number (P/N).

The complete Model WMA-1 Alarm Assembly includes the Model WMA-1 Water Motor Alarm, Model WM-1 Strainer, and Standard Inlet Trim.

WMA-1 Water Motor Alarm Assembly

Specify: Model WMA-1 Water Motor Alarm, (specify) Finish, P/N (specify):

Red Finish Gong P/N 52-630-1-001P
Aluminum Finish Gong. P/N 52-630-2-001P

Optional Drain Trim

Specify: Optional Drain Trim for Model WMA-1 Water Motor Alarm, P/N 52-630-2-002

Separately Ordered Parts for Multiple Systems

Specify: Model WM-1 Y-Strainer, P/N 52-271-1-001

Note: One Y-Strainer is required for two systems; two Y-Strainers are required for three systems.

Specify: 3/4 in. Check Valve with 3/32 in. Orifice, P/N 52-403-1-005

Note: Two Check Valves are required for two systems; three Check Valves are required for three systems.

Replacement Parts for Water Motor Alarm

Specify: (description) for use with Model WMA-1 Water Motor Alarm, P/N (see Figure 1)