

GRINNELL G-FIRE Figure 40-5 Strap (Pipe Outlet) Americas Only

General Description

The GRINNELL G-FIRE Figure 40-5 Strap is an economical alternative to welded pipe outlets on steel pipe. The Figure 40-5 Strap can be used with full lengths of pipe and eliminates welding, decreasing waste and installation time. The Figure 40-5 Strap can be used in wet, dry pipe, and deluge systems and is rated to a maximum pressure of 175 psi (12 bar).

NOTICE

The Figure 40-5 Strap described herein must be installed and maintained in compliance with this document, and with the applicable standards of the National Fire Protection Association, in addition to the standards of any authorities having jurisdiction. Failure to do so may impair the performance of this device.

Owners are responsible for maintaining their fire protection system and devices in proper operating condition. Contact the installing contractor or product manufacturer with any questions.

Technical Data

Approvals
UL and ULC Listed
FM Approved

Sizes
Pipe Run: 1-1/4 to 2-1/2 inch (DN32 to DN65)

Outlet Thread: 1/2 to 1 Inch NPT

Housing
Ductile iron conforming to ASTM A536, Grade 65-45-12

Protective Coatings
Clear rust inhibitive coating

Bolts/Nuts

- ANSI
The U-bolt is made from carbon steel conforming to ASTM A307 Grade A and zinc-electroplated conforming to ASTM B633.

The flange nuts are made from carbon steel conforming to ASTM A563 Grade A, and zinc electroplated per ASTM B633.

- Stainless Steel U-Bolts and Nuts are available upon request.

Gasket

Refer to data sheet TFP1895 for additional gasket information.



Fitting Size ANSI Inches	Equivalent Ft. Length (1 inch Sch. 40 pipe)
1-1/4 x 1	8
1-1/2 x 1	6
2 x 1	
2-1/2 x 1	4

Hazen Williams coefficient = 120

The 1 inch outlets can be used with a nipple leading directly to a sprinkler. These fittings should be used for hydraulically calculated systems only.

**TABLE A
FIGURE 40-5 STRAP
FRICTION LOSS AS
EQUIVALENT PIPE LENGTH
(1 INCH OUTLETS ONLY)**

Nominal Run Size ANSI Inches (DN)	O.D. Inches (mm)	Outlet Size NPT	Nominal Dimensions Inches (mm)				Approx. Weight Lbs. (kg)
			A	B	C	D	
1-1/4 (32)	1.660 (42,4)	1/2	2.00 (50,8)	1.50 (38,1)	3.50 (88,9)	1.20 (30,5)	0.84 (0,4)
		3/4	2.00 (50,8)	1.50 (38,1)	3.50 (88,9)	1.20 (30,5)	0.88 (0,4)
		1	2.31 (58,7)	1.68 (42,7)	3.50 (88,9)	1.20 (30,5)	1.13 (0,5)
1-1/2 (40)	1.900 (48,3)	1/2	2.12 (53,8)	1.62 (41,1)	3.50 (88,9)	1.32 (33,5)	0.84 (0,4)
		3/4	2.12 (53,8)	1.62 (41,1)	3.50 (88,9)	1.32 (33,5)	0.88 (0,4)
		1	2.43 (61,7)	1.80 (45,7)	3.50 (88,9)	1.32 (33,5)	1.13 (0,5)
2 (50)	2.375 (60,3)	1/2	2.36 (59,9)	1.86 (47,2)	3.74 (95,0)	1.55 (39,4)	0.88 (0,4)
		3/4	2.36 (59,9)	1.86 (47,2)	3.74 (95,0)	1.55 (39,4)	0.95 (0,4)
		1	2.67 (67,8)	2.04 (51,8)	3.74 (95,0)	1.55 (39,4)	1.16 (0,5)
2-1/2 (65)	2.875 (73,0)	1/2	2.61 (66,3)	2.11 (53,6)	4.25 (108,0)	1.80 (45,7)	0.90 (0,4)
		3/4	2.61 (66,3)	2.11 (53,6)	4.25 (108,0)	1.80 (45,7)	0.99 (0,5)
		1	2.92 (74,2)	2.29 (58,2)	4.25 (108,0)	1.80 (45,7)	1.21 (0,5)

Outlet Hole Size on Pipe is 1-3/16 inch (30,2 mm) diameter.

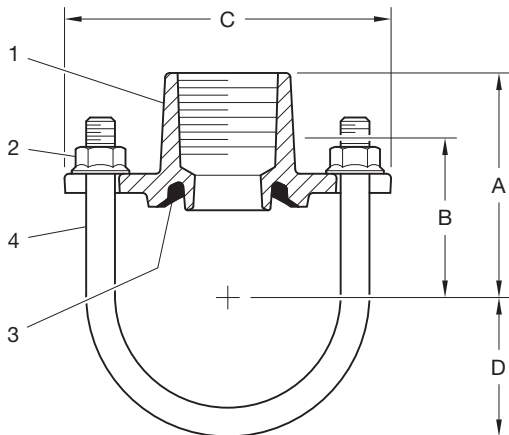

Item	Description
1	Housing
2	Flanged Nut
3	Gasket
4	U-Bolt

FIGURE 1
FIGURE 40-5 STRAP (PIPE OUTLET)
NOMINAL DIMENSIONS

Nominal Pipe Sizes ANSI Inches	Pipe Schedule ^a	Pressure Rating psi (bar)		
		UL	ULC	FM
1-1/4 x 1/2; 3/4; 1 1-1/2 x 1/2; 3/4; 1 2 x 1/2, 3/4; 1 2-1/2 x 1/2; 3/4; 1	10	175 (12)	175 (12)	175 (12)
	40	175 (12)	175 (12)	175 (12)

a. See Agency website for Listing/Approvals of other pipe specifications:
 UL Website - see Online Certificate Directory, www.ul.com
 FM Global Website - www.approvalguide.com

TABLE B
LISTED/APPROVED PRESSURE RATINGS

Care and Maintenance

The GRINNELL G-FIRE Figure 40-5 Strap must be maintained in accordance with this section.

Before closing a fire protection system main control valve for maintenance work on the fire protection system that it controls, obtain permission to shut down the affected fire protection system from the proper authorities and notify all personnel who may be affected by this decision.

After placing a fire protection system in service, notify the proper authorities and advise those responsible for monitoring proprietary and/or central station alarms.

The owner is responsible for the inspection, testing, and maintenance of their fire protection system and devices in compliance with this document, as well as with the applicable standards of the National Fire Protection Association (e.g., NFPA 25), in addition to the standards of any authority having jurisdiction. Contact the installing contractor or product manufacturer with any questions. Any impairments must be immediately corrected.

Automatic sprinkler systems are recommended to be inspected, tested, and maintained by a qualified Inspection Service in accordance with local requirements and/or national codes.

Limited Warranty

For warranty terms and conditions, visit www.tyco-fire.com.

Ordering Procedure

GRINNELL Products are available globally through a network of distribution centers. For the nearest distributor, visit www.tyco-fire.com. When placing an order, indicate the full product name.

Specify: G-FIRE Figure 40-5 Strap, (size), (quantity), P/N (specify):

- 1-1/4" x 1/2 NPT STP1305ES
- 1-1/4" x 3/4 NPT STP1307ES
- 1-1/4" x 1 NPT STP1310ES
- 1-1/2" x 1/2 NPT STP1505ES
- 1-1/2" x 3/4 NPT STP1507ES
- 1-1/2" x 1 NPT STP1510ES
- 2" x 1/2 NPT STP2005ES
- 2" x 3/4 NPT STP2007ES
- 2" x 1 NPT STP2010ES
- 2-1/2" x 1/2 NPT STP2505ES
- 2-1/2" x 3/4 NPT STP2507ES
- 2-1/2" x 1 NPT STP2510ES