

Model RV-1 Pressure Relief Valve, Pilot-Operated, Globe and Angle Body Styles

General Description

The TYCO Model RV-1 Pressure Relief Valves, 2 through 8 inch (DN50 through DN200), are factory assembled and fully trimmed valve arrangements for relief of excess water pressure. These valves are typically used to automatically relieve excess pressure in a fire protection system that utilizes a fire pump. Pilot-controlled, the Model RV-1 Valve maintains a relatively constant system pressure at the pump discharge as flow demands change.

The Model RV-1 Pressure Relief Valve may be field-set to a nominal relief “set pressure” of 30 to 250 psi (2,1 to 17,2 bar).

Features:

- Globe or angle pattern
- Installation in any orientation
- One-piece, one-moving-part diaphragm
- Ceramic enamel-coated interior
- Standard Epoxy-coated exterior
- Accurate pressure control
- In-line service
- No need to bleed trapped air from the diaphragm chamber
- One pilot valve sub-assembly that provides for any outlet “set pressure”; that is; 30 to 250 psi (2,1 to 17,2 bar)

NOTICE

The TYCO Model RV-1 Pressure Relief Valves described herein must be installed and maintained in compliance with this document and with the applicable standards of the National Fire Protection Association, in addition to the standards of any authorities having jurisdiction. Failure to do so may impair the performance of these devices.

IMPORTANT

Refer to Technical Data Sheet TFP2300 for warnings pertaining to regulatory and health information.

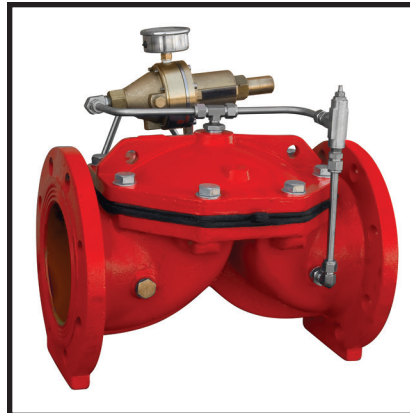

Body Style	End Connection	Nominal Valve Size				
		2 Inch (DN50)	3 Inch (DN80)	4 Inch (DN100)	6 Inch (DN150)	8 Inch (DN200)
Globe	Flange x Flange	✓	✓	✓	✓	✓
Angle	Thread x Thread	✓	N/A	N/A	N/A	N/A
	Flange x Flange	N/A	✓	✓	✓	✓
		✓ Available	N/A = Not Available			

The owner is responsible for maintaining their fire protection system and devices in proper operating condition. Contact the installing contractor or product manufacturer with any questions.

Technical Data

Approvals
UL Listed
FM Approved

Maximum Inlet Pressure
250 psi (17,2 bar)

Temperature Range
50°F to 175°F (10°C to 80°C)

Field Relief “Set Pressure” Range
30 to 250 psi (2,1 to 17,2 bar)

NFPA 20 Recommended Maximum Flow

2 in. (DN50)	250 GPM (946 LPM)
3 in. (DN80)	500 GPM (1893 LPM)
4 in. (DN100)	1000 GPM (3785 LPM)
6 in. (DN150)	2500 GPM (9462 LPM)
8 in. (DN200)	5000 GPM (18925 LPM)

Refer also to Graph A for inlet pressure versus flow characteristics.

End Connections

Threaded end connections are available as NPT threaded or threaded per ISO 7-1. Flanged end connections are available as drilled per Table A.

Construction (Figure 2)

Body
Standard Epoxy-coated exterior, ductile iron per ASTM A536-77, Grade 65-45-12

Diaphragm Cover
Standard Epoxy-coated exterior, ductile iron per ASTM A536-77, Grade 65-45-12

Diaphragm
Nylon fabric-reinforced, natural rubber per ASTM D2000

Diaphragm Cover Fasteners
Galvanized carbon steel

Pilot Valve
Cast bronze and stainless steel with nylon fabric reinforced, natural rubber per ASTM D2000 diaphragm

Pressure Gauges

2-1/2 inch (65 mm) diameter, stainless steel case, 0 to 350 psi (25 bar)

Strainer, Tube, Fittings, and Needle Valve

Stainless steel

Operation

The TYCO Model RV-1 Pressure Relief Valve is normally installed on-line in a tee configuration (Figure 1), after the fire pump and before the system's check valve.

When the Model RV-1 Pressure Relief Valve opens to permit excess flow and to relieve pressure to the atmosphere within the water tank, the fire protection system is accurately maintained at the desired preset pressure. In case the demand of the fire system completely stops, the Model RV-1 Pressure Relief Valve remains fully open, relieving 100% of the pump's capacity.

The check valve then closes, isolating the system from the pump. The pump shuts off safely, avoiding the risk of system surges. As the pump shuts, the Model RV-1 Pressure Relief Valve slowly closes.

The operation sequence (Ref. Figure 3) is as follows:

- When inlet pressure is below the relief "set pressure", the Model RV-1 Pressure Relief Valve Diaphragm Seat is closed and the Pilot Valve Seat is closed. With the Pilot Valve Seat closed, pressure is trapped in the Diaphragm Chamber to seat the Diaphragm, and the Model RV-1 Pressure Relief Valve remains closed.
- When inlet pressure is above the relief "set pressure", the Pilot Valve Seat opens to relieve pressure from the Diaphragm Chamber faster than pressure can be re-established through the Needle Valve. Loss of pressure in the Diaphragm Chamber allows the Model RV-1 Pressure Relief Valve to open.
- Subsequent to relieving excess pressure, when the inlet pressure starts to fall below the relief "set pressure", the Pilot Valve Seat closes to allow the Diaphragm Chamber to re-pressurize automatically and close the Model RV-1 Pressure Relief Valve. The restriction orifice provided by the Needle Valve controls the speed at which the Model RV-1 Valve closes to provide a slow re-closure.

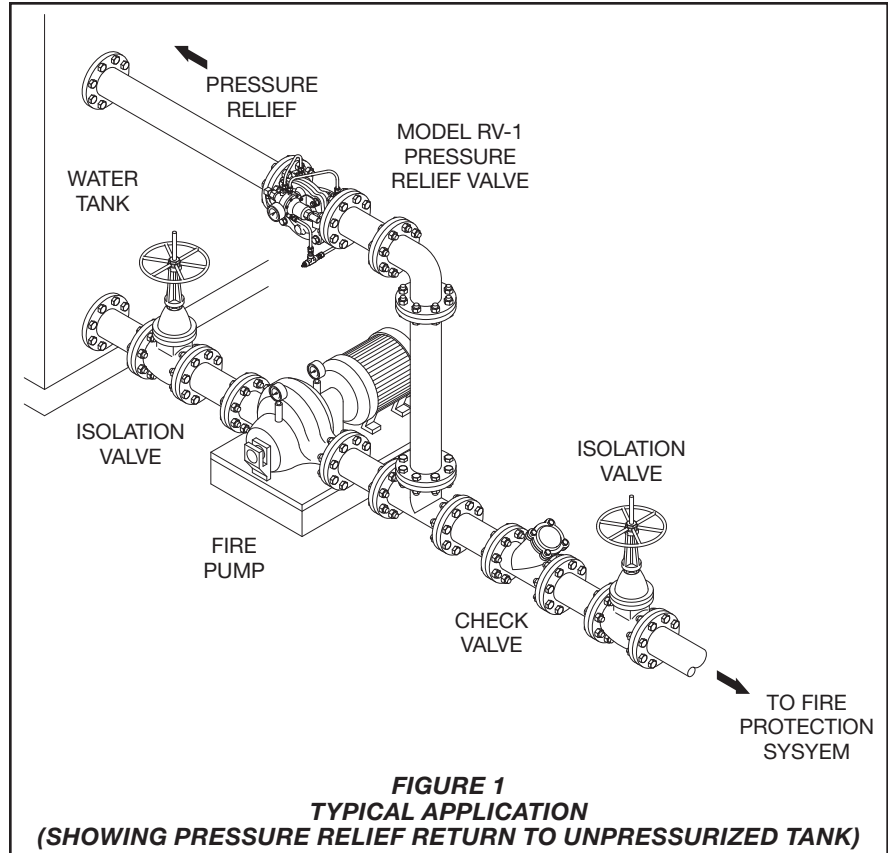

Design Considerations

The following items must be considered and applied accordingly for an installation that will be using the TYCO Model RV-1 Pressure Relief Valve:

- The Model RV-1 Pressure Relief Valve may be installed vertically or horizontally and in any orientation without affecting its operating efficiency. When planning the positioning of the Model RV-1 Valve, it is recommended that consideration be given to the viewing of the pressure gauge. Consideration should also be given to positioning the Model RV-1 Valve so that the diaphragm cover is facing up. With the cover facing up, internal access is more easily achieved.
- The installation of an isolation valve in the inlet connection to the Model RV-1 Pressure Relief Valve is recommended to facilitate performing preventative main-

tenance on the Model RV-1 Valve. Isolating valves installed per Figure 1 will meet this recommendation in addition to providing isolation means for the fire pump, water tank, and fire protection system.

- The Model RV-1 Pressure Relief Valve must be in an area that is easily accessible for maintenance purposes, not subject to freezing temperatures, and not subject to physical damage.
- The Model RV-1 Pressure Relief Valve is designed for fresh water service. When corrosive atmospheres and/or contaminated water supplies are present, responsibility lies with owners to verify compatibility with the pressure relief valve, pilot valve, and trim.

VALVE PARTS		
NO.	DESCRIPTION	QTY. KIT
1	Valve Body	1 NR
2	Diaphragm	1 (a)
3	Diaphragm Cover	1 NR
4	Flat Washer,	
	2 Inch Valve, M12	4 CH
	3 & 4 Inch Valves, M16	4 CH
	6 & 8 Inch Valves, M16	8 CH
5	Hex Bolt,	
	2 Inch Valve, M12 x 35	4 CH
	3 & 4 Inch Valves,	
	M16 x 55	4 CH
	6 Inch Valve, M16 x 45	8 CH
	8 Inch Valve, M16 x 55	8 CH
6	Hex Nut, M16,	
	4 Inch Valve Only	4 CH
7	Pilot Valve	1 (b)
8	Water Pressure Gauge	1 (c)
9	Strainer	1 (d)
10	Tubing and Fittings	1 (e)

REPLACEMENT PART KITS		
KIT	DESCRIPTION	P/N
(a)	Diaphragm, Fits Either Body Style, Includes Item 2 only:	
	2 Inch Valves	92-570-2-011
	3 Inch Valves	92-570-2-012
	4 Inch Valves	92-570-2-013
	6 Inch Valves	92-570-2-014
	8 Inch Valves	92-570-2-015
(b)	Pilot Valve	92-572-2-200
(c)	Water Pressure Gauge	92-570-2-211
(d)	Strainer:	
	2, 3, & 4 Inch Valves	92-570-2-202
	6 & 8 Inch Valves	92-570-2-209
(e)	Tubing and Fitting Kit, Excludes Items 7, 8, 9, and 10	
	Globe Style Valve:	
	2 Inch Valve	92-572-3-001
	3 Inch Valve	92-572-3-002
	4 Inch Valve	92-572-3-003
	6 Inch Valve	92-572-3-004
	8 Inch Valve	92-572-3-005
	Angle Style Valve:	
	2 Inch Valve	92-573-3-001
	3 Inch Valve	92-573-3-002
	4 Inch Valve	92-573-3-003
	6 Inch Valve	92-573-3-004
	8 Inch Valve	92-573-3-005

NOTES:

- NR - Not Replaceable
- CH - Common Hardware

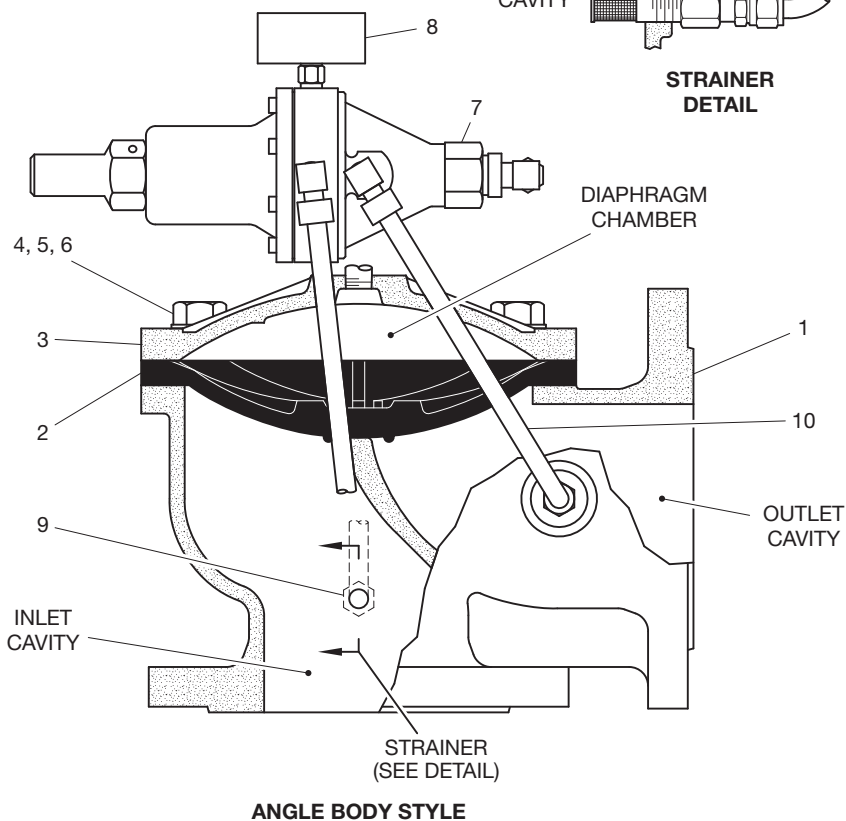
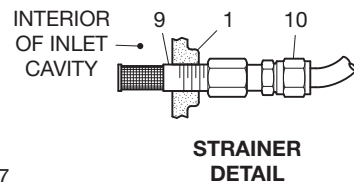
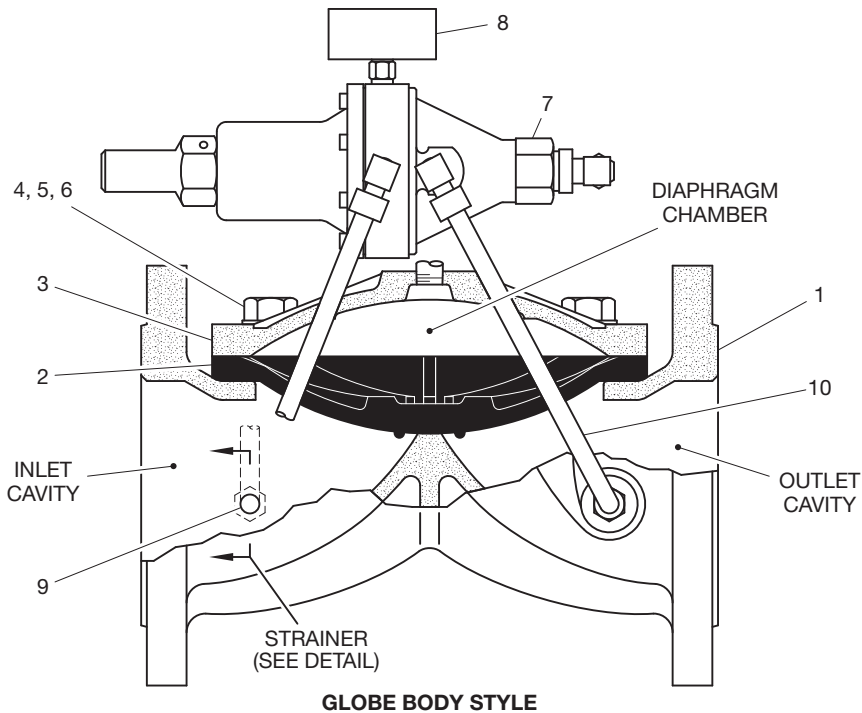
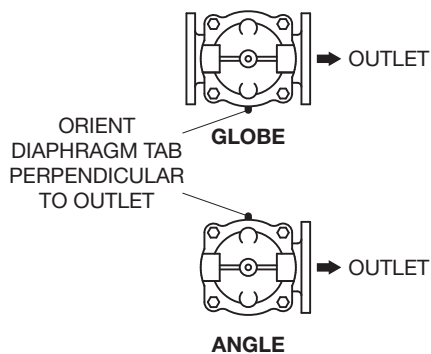
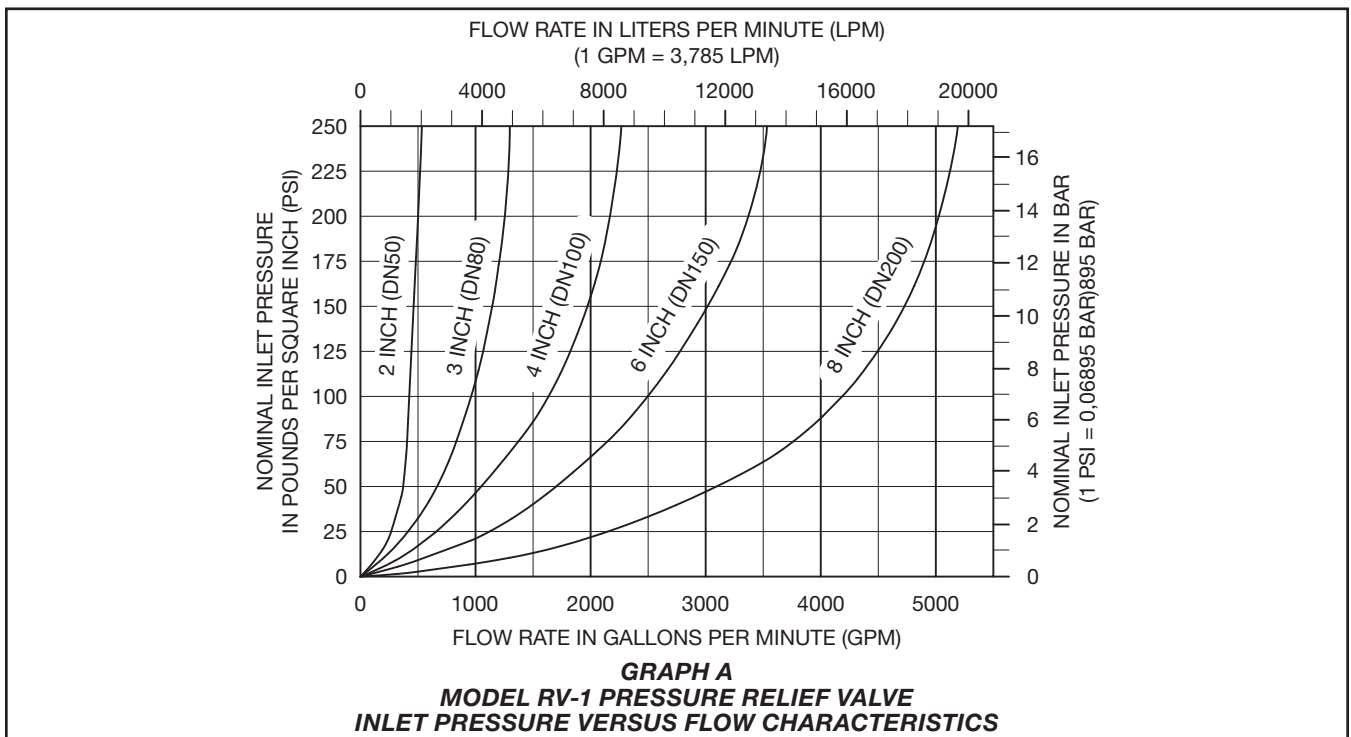
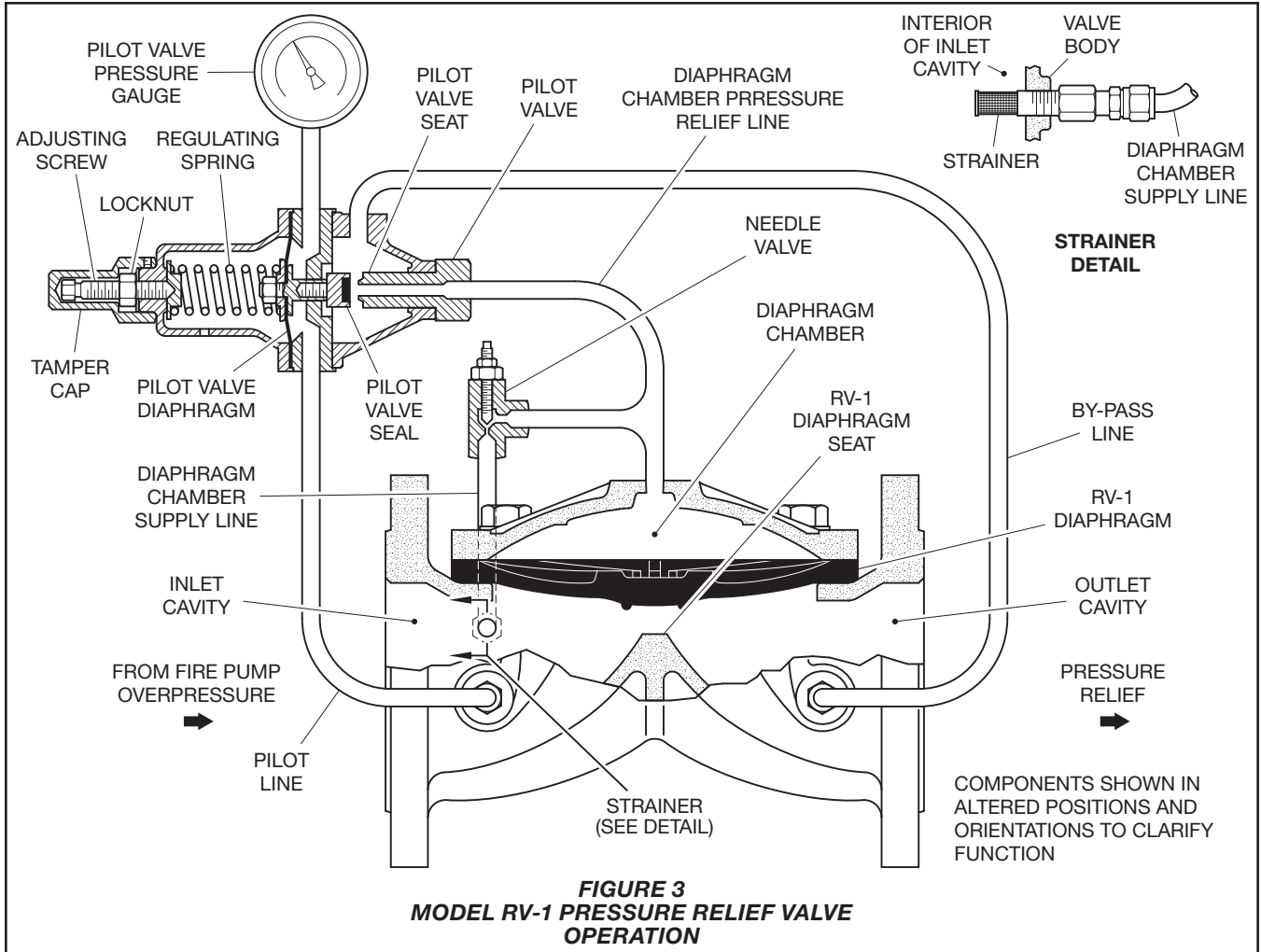

FIGURE 2
MODEL RV-1 PRESSURE RELIEF VALVE
ASSEMBLY



Installation

The TYCO Model RV-1 Pressure Relief Valve must be installed with the flow arrow located on the Diaphragm Cover pointing in the intended direction of flow. Installation dimensions are provided in Figures 5 and 6 for both body styles.

Before installing the Model RV-1 Pressure Relief Valve, flush pipe lines to remove all chips, scale, and foreign matter. Exercise care to assure that the trim is not damaged during installation.

NOTICE

Do not lift the valve by its trim. Otherwise, the trim may be damaged and impair system operation.

Make the inlet and outlet connections based on the direction of arrow provided on the Diaphragm Cover. The valve cannot operate if connected backwards.

Do not alter the trim. Altering the trim will render the valve ineffective and impair system operation.

Placing the Valve in Service

Perform Steps 1 through 5 when placing the TYCO Model RV-1 Pressure Relief Valve in service.

NOTICE

Pressure relief adjustment is only to be performed by experienced personnel who understand the impact of adjusting the pressure relief setting and who take full responsibility of the relief setting.

Prior to pressurizing the Model RV-1 Pressure Relief Valve, make sure the necessary pressure gauges to measure pressure in the system are installed as required by the system designer.

Note: *Venting any trapped air from the Diaphragm Chamber is not necessary.*

1. Loosen the Pilot Valve Locknut, then completely loosen the Adjusting Screw. Tighten the Adjusting Screw three turns beyond the point at which spring resistance is encountered.
2. Loosen the Needle Valve Locknut, completely tighten the Needle Valve Adjusting Screw, loosen the Needle Valve Adjusting Screw one turn, and tighten the Needle Valve Locknut.
3. Start the pump. One hundred percent of pump capacity will now flow through the Model RV-1 Pressure Relief Valve into the tank."
4. Slowly tighten the Pilot Valve Adjusting Screw until the desired relief "set pressure" is achieved on the

Pilot Valve Pressure Gauge. Make all pilot adjustments slowly and in small increments.

5. Tighten the Locknut and shut off the pump.

Note: *After any pressure adjustment, the following items are to be recorded on a tag attached to the valve:*

- Valve installation location
- Inlet static pressure
- Relief set pressure

The tag is not to be removed until after the system has been accepted by the Authority Having Jurisdiction. It is recommended that the tag not be removed even after acceptance by the Authority Having Jurisdiction unless another means of record-keeping is maintained.

Care and Maintenance

Inspection, testing, and maintenance must be performed in accordance with the requirements of the NFPA. Any impairment must be immediately corrected. Refer to Table B for information on troubleshooting valve problems.

The owner is responsible for the inspection, testing, and maintenance of their fire protection system and devices in compliance with this document, as well as with the applicable standards of any authorities having jurisdiction. Contact the installing contractor or product manufacturer with any questions.

Automatic sprinkler systems are recommended to be inspected, tested, and maintained by a qualified Inspection Service in accordance with local requirements and/or national codes.

Note: *Before closing a fire protection system main control valve for maintenance work on the fire protection system that it controls, obtain permission to shut down the affected fire protection systems from the proper authorities and notify all personnel who may be affected by this decision.*

The TYCO Model RV-1 Pressure Relief Valve requires no lubrication, packing or preventative maintenance. However, replacement of the diaphragm every five years is recommended.

Inspections

- Inspect the Model RV-1 Pressure Relief Valve on a weekly basis.
- Check the valve under static conditions to assure that the Model RV-1 Pressure Relief Valve is not unnecessarily relieving pressure. If necessary, re-adjust the Model RV-1 Pressure Relief Valve by following the instructions in the

section Placing the Valve in Service. If the desired pressure cannot be achieved, the Diaphragm and/or Pilot Valve should be replaced.

- During pump start-ups, check that the Model RV-1 Pressure Relief Valve relieves pressure as necessary. If necessary, re-adjust the Model RV-1 Pressure Relief Valve by following the instructions in the section Placing the Valve in Service. If the desired pressure cannot be achieved, the Diaphragm and/or Pilot Valve should be replaced.
- Check that the Model RV-1 Pressure Relief Valve, Pilot Valve, Tube, Fittings, Needle Valve, and Pressure Gauge are in good condition and do not exhibit signs of damage or leakage.
- Make sure that the Pilot Valve Locknut is securely tightened.

Diaphragm Replacement

Prior to replacing the Diaphragm, the Model RV-1 Pressure Relief Valve must be taken out of service and completely drained.

With reference to Figure 2, the Diaphragm Tab is oriented perpendicular to the outlet flow. When reinstalling the Diaphragm Cover, the Diaphragm Cover Fasteners must be uniformly and securely tightened using a cross-draw sequence. After tightening, double check to make certain that all Diaphragm Cover fasteners are securely tightened.

Pilot Valve Replacement

Prior to removing the Pilot Valve, the Model RV-1 Pressure Relief Valve must be taken out of service and completely drained.

When installing the replacement Pilot Valve, the trim components must be replaced exactly as they were. After reinstalling the Pilot Valve and before returning the Model RV-1 Pressure Relief Valve into service, completely unscrew the Adjusting Screw. Then, to place the Model RV-1 Pressure Relief Valve in service, follow the instructions in the section Placing the Valve in Service.

NOTICE

The Pilot Valve is not field repairable. Attempting to repair the Pilot Valve may render the valve ineffective and impair the system operation.

Completely unscrewing the Adjusting Screw of the replacement Pilot Valve will help to avoid an accidental over-pressurization of the system piping prior to achieving the desired relief "set pressure".

Flange x Flange End Connections						
Nominal Valve Size Inches (DN)	Nominal Installation Dimensions in Inches and (mm)					Weight lbs (kg)
	A	B	C	D	E	
2 (DN50)	7.48 (190)	3.15 (80)	8.27 (210)	6.50 (165)	4.72 (120)	23.2 (10,5)
3 (DN80)	11.22 (285)	3.94 (100)	8.66 (220)	7.48 (190)	5.91 (150)	46.7 (21,2)
4 (DN100)	12.00 (305)	4.53 (115)	9.45 (240)	7.68 (195)	6.50 (165)	64.2 (29,1)
6 (DN150)	16.14 (410)	5.71 (145)	10.43 (265)	9.45 (240)	5.12 (130)	118.0 (53,5)
8 (DN200)	18.50 (470)	6.10 (155)	11.42 (290)	11.02 (280)	6.69 (170)	166.0 (75,3)

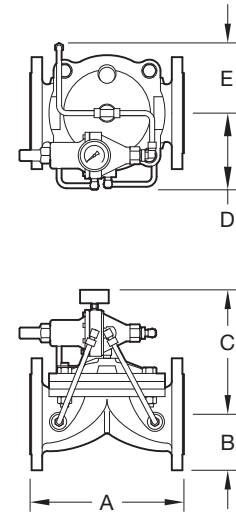
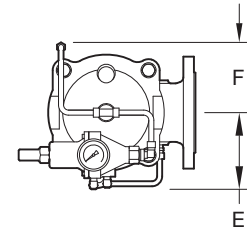

FIGURE 4
MODEL RV-1 PRESSURE RELIEF VALVE
GLOBE STYLE INSTALLATION DIMENSIONS

Thread x Thread End Connections						
Nominal Valve Size Inches (DN)	Nominal Installation Dimensions in Inches and (mm)					Weight lbs (kg)
	A	B	C	D	E	
2 (DN50)	3.35 (85)	3.15 (80)	8.46 (215)	5.51 (140)	6.10 (155)	15.9 (7,2)



Flange x Flange End Connections						
Nominal Valve Size Inches (DN)	Nominal Installation Dimensions in Inches and (mm)					Weight lbs (kg)
	A	B	C	D	F	
3 (DN80)	6.10 (155)	4.33 (110)	9.45 (240)	6.10 (155)	7.48 (190)	35.1 (15,9)
4 (DN100)	6.50 (165)	4.53 (115)	10.63 (270)	6.10 (155)	7.87 (200)	67.3 (30,5)
6 (DN150)	7.87 (200)	5.91 (150)	11.61 (295)	4.53 (115)	9.45 (240)	118.0 (53,5)
8 (DN200)	8.66 (220)	6.69 (170)	12.20 (310)	5.91 (150)	11.22 (285)	168.0 (76,2)

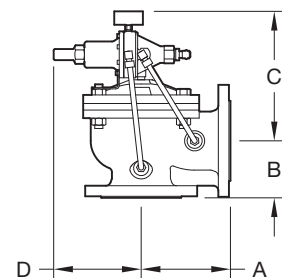
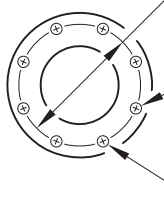

FIGURE 5
MODEL RV-1 PRESSURE RELIEF VALVE
ANGLE STYLE INSTALLATION DIMENSIONS

Nominal Valve Size Inches (DN)	Flange Drilling Specification														
	Nominal Installation Dimensions in Inches and (mm)														
	ANSI B16.11 ^a (Class 125)			ISO 7005-2 (PN10) ^{2b}			ISO 7005-2 (PN16) ^{3c}			JIS B 2210 (10K)			AS 2129 (Table E)		
	A	B	N	A	B	N	A	B	N	A	B	N	A	B	N
2 (DN50)	4.75 (120,7)	0.75 (19,0)	4	USE ISO 7005-2 (PN16)	4.92 (125,0)	0.75 (19,0)	4	4.72 (120,0)	0.59 (15,0)	4	4.49 (114,0)	0.71 (18,0)	4		
3 (DN80)	6.00 (152,4)	0.75 (19,0)	4		6.30 (160,0)	0.75 (19,0)	8	5.90 (150,0)	0.59 (15,0)	8	5.75 (146,0)	0.71 (18,0)	4		
4 (DN100)	7.50 (190,5)	0.75 (19,0)	8		7.09 (180,0)	0.75 (19,0)	8	6.89 (175,0)	0.60 (15,0)	8	7.00 (178,0)	0.71 (18,0)	8		
6 (DN150)	9.50 (241,3)	0.88 (22,2)	8		9.45 (240,0)	0.91 (23,0)	8	9.45 (240,0)	0.75 (19,0)	8	9.25 (235)	0.87 (22,0)	8		
8 (DN200)	11.75 (298,5)	0.88 (22,2)	8		11.61 (295,0)	0.91 (23,0)	8	11.61 (295,0)	0.91 (23,0)	12	11.42 (290,0)	0.75 (19,0)	12	11.50 (292,0)	0.87 (22,0)



Dim. A Bolt Circle Diameter
Dim. B Bolt Hole Diameter
Qty. N Number of Bolt Holes

Notes:
a. Same drilling as for ANSI B16.5 (Class 150) and ANSI B16.42 (Class 150)
b. Same drilling as for BS 4504 Section 3.2 (PN10) and DIN 2532 (PN10)
c. Same drilling as for BS 4504 Section 3.2 (PN16) and DIN 2532 (PN16)

TABLE A
DIMENSIONAL SPECIFICATION FOR SELECTION OF FLANGE DRILLING

PROBLEM	CAUSE	SOLUTION
Valve fails to open	<ol style="list-style-type: none"> 1. Water connections are blocked 2. Pilot adjustment is too high 3. Pilot diaphragm or seal is damaged 	<ol style="list-style-type: none"> 1. Dismantle and clean downstream tubing* 2. Reset pressure by turning pressure adjusting screw CCW 3. Replace pilot valve*
Valve fails to close	<ol style="list-style-type: none"> 1. Water connections are blocked 2. Blocked or stuck needle valve 3. Blocked finger filter 4. Foreign object stuck under valve diaphragm 5. Valve diaphragm is leaking 6. Pilot seal is damaged. 	<ol style="list-style-type: none"> 1. Dismantle and clean upstream tubing* 2. Dismantle and clean needle valve* 3. Dismantle and clean finger filter* 4. Loosen cover bolts, remove cover and diaphragm, and dispose of foreign object* 5. Loosen cover bolts and replace diaphragm* 6. Replace pilot valve*

* Prior to performing solution, the Model RV-1 must be taken out of service and completely drained.

TABLE B
TROUBLESHOOTING PROCEDURE

Limited Warranty

For warranty terms and conditions, visit
www.tyco-fire.com.

Ordering Procedure

Contact your local distributor for availability. When placing an order, indicate the full product name and Part Number (P/N).

Pressure Relief Valve

Specify: Model RV-1 Valve, (specify body type), size (specify), Connection Type (specify Threaded NPT or ISO, or Flanged, including flange drilling specification from below), and P/N (specify):

- Valve Type and Size
 - Globe: 2, 3, 4, 6, or 8 Inch
 - Angle: 2, 3, 4, 6, or 8 Inch
- Connection Type — Threaded or Flanged
 - For threaded, specify NPT or ISO
 - For flanged, identify flange drilling specification as follows:
 - ANSI B16-1 (Class 125)
 - ISO 7005-2 (PN16)
 - ISO 7005-2 (PN10) (8 Inch valve only)
 - JIS B2210 (10K)
 - AS 2129 (Table E)
 - Table A describes the flange drilling dimensional specifications listed above.

Globe Body Style

2 in. F x F	
ANSI Flange	52-572-8-010
2 in. F x F	
ISO (PN16) Flange	52-572-8-130
2 in. F x F	
JIS Flange	52-572-8-710
2 in. F x F	
AS Flange	52-572-8-510
3 in. F x F	
ANSI Flange	52-572-8-022
3 in. F x F	
ISO (PN16) Flange	52-572-8-112
3 in. F x F	
JIS Flange	52-572-8-722
3 in. F x F	
AS Flange	52-572-8-522
4 in. F x F	
ANSI Flange	52-572-8-023
4 in. F x F	
ISO (PN16) Flange	52-572-8-113
4 in. F x F	
JIS Flange	52-572-8-723
4 in. F x F	
AS Flange	52-572-8-523
6 in. F x F	
ANSI Flange	52-572-8-025
6 in. F x F	
ISO (PN16) Flange	52-572-8-115
6 in. F x F	
JIS Flange	52-572-8-725
6 in. F x F	
AS Flange	52-572-8-525
8 in. F x F	
ANSI Flange	52-572-8-026
8 in. F x F	
ISO (PN10) Flange	52-572-8-116
8 in. F x F	
ISO (PN16) Flange	52-572-8-126
8 in. F x F	
JIS Flange	52-572-8-726
8 in. F x F	
AS Flange	52-572-8-526

Angle Body Style

2 in. T x T	
NPT	52-573-8-060
2 in. T x T	
ISO	52-573-8-160
3 in. F x F	
ANSI Flange	52-573-8-022
3 in. F x F	
ISO (PN16) Flange	52-573-8-112
3 in. F x F	
JIS Flange	52-573-8-722
3 in. F x F	
AS Flange	52-573-8-522
4 in. F x F	
ANSI Flange	52-573-8-023
4 in. F x F	
ISO (PN16) Flange	52-573-8-113
4 in. F x F	
JIS Flange	52-573-8-723
4 in. F x F	
AS Flange	52-573-8-523
6 in. F x F	
ANSI Flange	52-573-8-025
6 in. F x F	
ISO (PN16) Flange	52-573-8-115
6 in. F x F	
JIS Flange	52-573-8-725
6 in. F x F	
AS Flange	52-573-8-525
8 in. F x F	
ANSI Flange	52-573-8-026
8 in. F x F	
ISO (PN10) Flange	52-573-8-116
8 in. F x F	
ISO (PN16) Flange	52-573-8-126
8 in. F x F	
JIS Flange	52-573-8-726
8 in. F x F	
AS Flange	52-573-8-526

Replacement Valve Parts

Refer to Figure 2 for replacement parts.
Specify: Model RV-1 Pressure Relief Valve, (specify size), (specify part description), P/N (specify per Figure 2)