

## DV-5 Red-E Cabinet Integrated Deluge Fire Protection Package

### General Description

The TYCO DV-5 Red-E Cabinet is a pre-assembled fire protection valve package enclosed within a free-standing cabinet designed to occupy minimal floor space and to provide an aesthetically pleasing enclosure for a fire protection valve riser. The entire package is pre-wired and the water inlet and outlets to the valve riser are grooved to provide minimal installation time. The valve package includes the system (manual) shut-off control valve, automatic water control valve, and water-flow/supervisory switches. When dry pilot actuation is utilized, a built-in air compressor with associated controls provides an automatic air supply for the dry pilot lines.

Integral to the DV-5 Red-E Cabinet is a control panel and back-up batteries for providing electrical alarm, supervisory, and trouble functions. All switches within the cabinet are pre-wired to the control panel, making the electrical connections for power, detection circuits (as applicable), and alarms the only remaining connections to complete the system.

In addition to the control panel being integral to the DV-5 Red-E Cabinet, windows have been provided in the door for viewing the releasing panel functions and essential system pressure gauges. A lock for the control panel access door is standard, and a lock for the cabinet door is optional.

Features and benefits are as follows:

- aesthetically pleasing appearance
- professionally assembled
- internally wired
- custom manufactured
- all gauges and panel display are externally visible
- removable side panels for ease of maintenance
- furniture grade rollers (4) are standard at bottom of cabinet

The DV-5 Red-E Cabinet has been designed to readily incorporate 1-1/2 thru 8 inch (DN40 thru DN200) valve risers for the following types of deluge systems:

- Electric Actuation
- Dry Pilot Actuation
- Wet Pilot Actuation

#### NOTICE

*The DV-5 Red-E Cabinets described herein must be installed and maintained in compliance with this document and with the applicable standards of the National Fire Protection Association (NFPA), in addition to the standards of any authorities having jurisdiction. Failure to do so may impair the performance of these devices.*

*The owner is responsible for maintaining their fire protection system and devices in proper operating condition. Contact the installing contractor or product manufacturer with any questions.*

### Technical Data

#### Approvals

The 1-1/2 thru 8 inch (DN40 thru DN200) DV-5 Red-E Cabinets are UL Listed, C-UL Listed, and FM Approved with the following system types:

- Deluge with Electric Actuation
- Deluge with Dry Pilot Actuation
- Deluge with Wet Pilot Actuation

#### System Types

The technical data sheets referenced in Table B provide complete details for each system type arrangement.

#### Working Pressure Range

20 to 250 psi (1,4 to 17,2 bar)

#### Construction

The Red-E Cabinet is constructed of 14 gauge steel, and is free standing. The standard paint finish is bright red. The front door of the enclosure is fully hinged (and removable) and opens nearly to the cabinet floor level allowing easy access to the couplings when



connecting the water supply and drain. The cabinet roof is a removable panel that allows access to the Compressor. Pre-drilled holes in the cabinet floor provide an anchor point for the cabinet to be secured to the floor when required. All four sides of the cabinet can be removed for ease of maintenance, and furniture grade rollers at the bottom of the cabinet are standard. Internal controls that provide functions to reset a system after operation (e.g., alarm test valve, main drain valve, etc.) are individually tagged for easy identification. All prefabricated piping is Schedule 40 steel.

A Splash-Proof Drain Cup is provided with a Splash Cover that ensures water does not splash into the cabinet during flow testing. The discharging water can be observed through the clear portion of the cover. It is designed with a fail-safe feature allowing water to overflow in the event the drain is blocked.

The Hard Piped Funnel Drain is connected through a Swing Check Valve to the Main Drain Header, eliminating the need to run a separate drain line from the funnel. The cabinet floor is provided with a drain opening to allow water to drain out. A plug is also provided to prevent water from draining from the cabinet if necessary.

For Dry Pilot Trim arrangements, the Air Supply connection for cabinets without compressors (that utilizes AMD-1) are terminated at a common height across

DIM	Description	Nominal Riser Size Nominal Dimension in Inches and (millimeters) <sup>1</sup>					
		1-1/2 (DN40)	2 (DN50)	3 (DN80)	4 (DN100)	6 (DN150)	8 (DN200)
A	System Discharge	1-1/2 (DN40)	2 (DN50)	3 (DN80)	4 (DN100)	6 (DN150)	8 (DN200)
B	Supply Header	3 (DN80)			6 (DN150)		8 (DN200)
C	Drain Header	2 (DN50)					
D	Header Left	12-1/4 (311)			16-1/2 (420)		17-3/4 (451)
E	Header Right	12-1/4 (311)			13 (330)		14-1/4 (362)
F	Riser Height	66 (1676)	66 (1676)	66 (1676)	74 (1880)	74 (1880)	78-3/4 (2000)
G	Connection Offset	9-1/4 (235)					
H	Connection Offset	10-1/8 (257)			14-1/8 (359)		15-1/8 (385)
J	Connection Offset	4-1/8 (105)			8-1/8 (206)		9-1/8 (232)
K	Connection Offset	6 (152)					
L	Connection Offset	5-1/8 (130)			5-1/8 (130)		
M	Connection Offset	14-1/4 (362)			16 (406)		15-1/2 (394)
N	Cabinet Height	70-9/16 (1792)			78-1/2 (1994)		82-5/8 (2099)
P	Cabinet Width	28-1/2 (725)			36 (915)		36 (914)
R	Cabinet Depth	20-1/2 (520)			28-3/16 (716)		32-3/16 (818)

1. All pipe connections are grooved
2. Supply and drain header connections made internal to cabinet

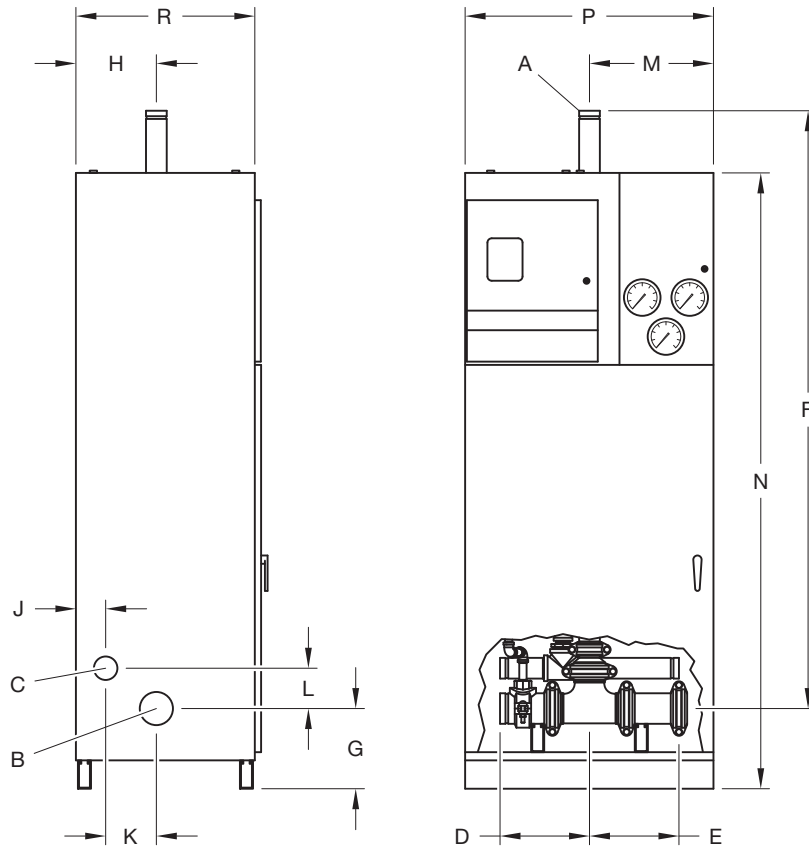

**FIGURE 1**  
**INSTALLATION DIMENSIONS AND REFERENCE POINTS**

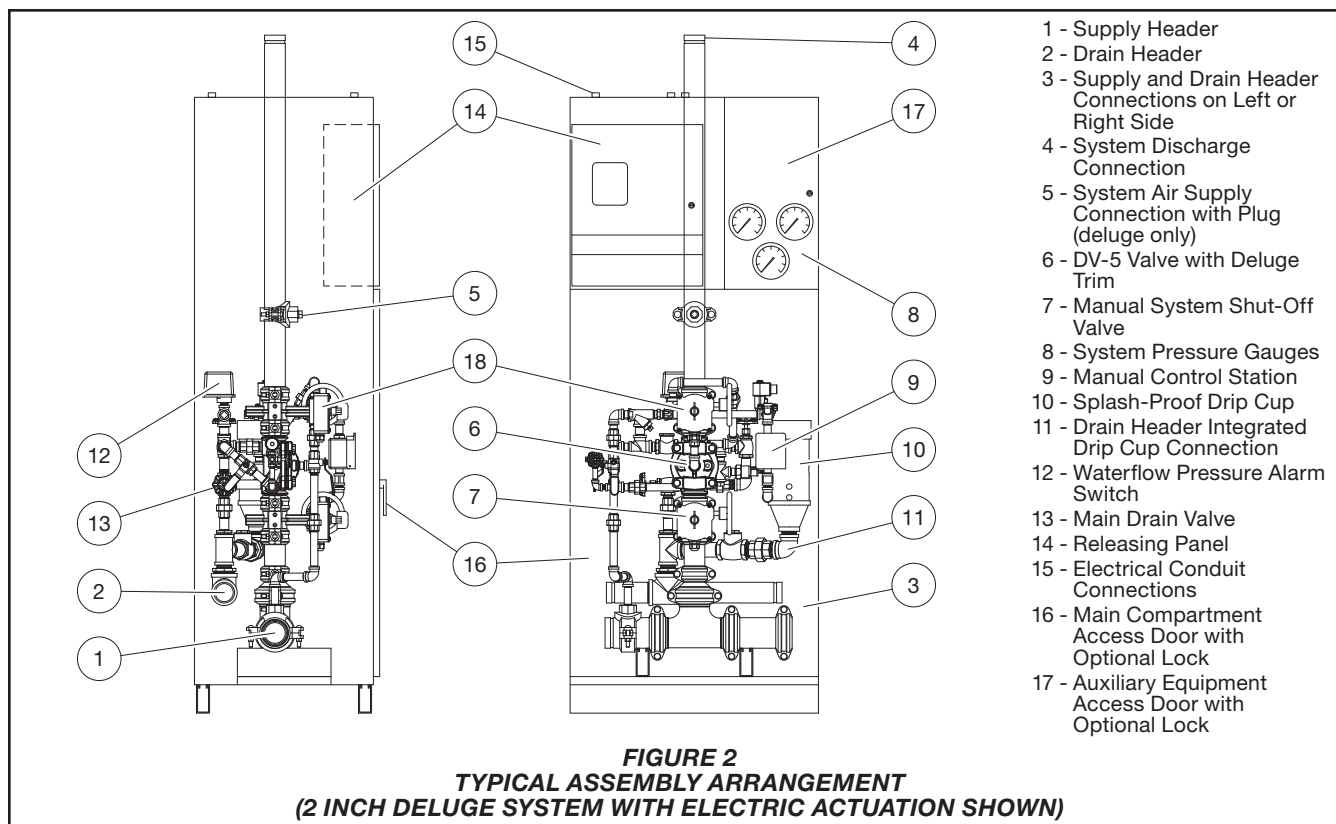

all model sizes allowing the connection of groups of cabinets easier. This allows a single tank mounted compressor sized to meet the requirements of the largest system in the group to supply all the cabinets in the group, or alternatively, connect to the factory air supply. The air supply line contains a tee and plug which is used to connect a hydraulic test pump that pressurizes the sprinkler system above the check valve for hydraulic testing of the system in accordance with NFPA 13.

Table A provides list of riser components and a cross reference to individual technical data sheets, as well as individual component laboratory approval information.

Figure 1 provides dimensional information for Red-E Cabinets, and Figure 2 illustrates the typical assembly arrangement.

## **Design Considerations**

The open nozzles and/or sprinklers, fire detection devices, manual pull stations, and signaling devices that are to be utilized with the Red-E Cabinet must be UL Listed, ULC Listed, C-UL Listed, or FM Approved, as applicable. With reference to Figure 3, the system designer must consider and make preparations for use of a Red-E Cabinet as follows:

- adequate floor space to facilitate opening of the cabinet door
- minimum ambient temperature of 40°F (4°C)
- installation of a suitably sized water supply to the water supply header (Port B, Fig. 1)
- installation of system piping (Port A, Fig. 1) including open nozzles and/or sprinklers from the Red-E cabinet outlet
- installation of drains from main drain header (Port C, Fig. 1)
- installation of the detection system components and alarms
- power supply to Red-E Cabinet
- separate power supply to the air compressor (dry pilot actuation)

## **Installation**

The TYCO DV-5 Red-E Cabinet is to be installed following the directions given in the Red-E Cabinet Installer's Manual provided with the Red-E Cabinet. Instructions pertain to the following items:

- placing the cabinet
- connecting the system piping
- electrical connections
- system start-up

Description	Model	Data Sheet	UL	C-UL/ULC	FM
System Shut-Off Valve, 1-1/2" (DN40)	Lansdale Powerball 51024A		X <sup>4</sup>	X <sup>4</sup>	X <sup>4</sup>
System Shut-Off Valve, 2"-8" (DN50-DN200)	BFV-300	TFP1511	X	X	X
Automatic Water Control Valve	DV-5	TFP1305	X	X	X
Actuation Trim					
Electric		TFP1320	X	X	X
Dry Pilot		TFP1315	X	X	X
Wet Pilot		TFP1310	X	X	X
Pressure Alarm Switch	PS10-2A		X <sup>5</sup>	X <sup>5</sup>	X <sup>5</sup>
Pressure Alarm Switch	PS40-2A		X <sup>5</sup>	X <sup>5</sup>	X <sup>5</sup>
Control Panel <sup>1</sup>	PFC-4410RC		X <sup>5</sup>	X <sup>5</sup>	X <sup>5</sup>
Air Maintenance Device <sup>2</sup> , Regulator Type	AMD-1	TFP1221	X	X	X
Air Maintenance Device <sup>3</sup> , Switch Type	AMD-2	TFP1231	X	X	X
Nitrogen Maintenance Device <sup>3</sup>	AMD-3	TFP1241	X	X	X

**Notes:**

- The Model PFC-4410RC is standard. The Red-E Cabinet may be ordered without an integral control panel.
- The Model AMD-1 Air Maintenance Device, in addition to an Auxiliary Air Tank, is utilized as standard equipment for Dry Pilot Actuation. In the case of Dry Pilot Actuation, the automatic air supply is utilized for the air pressure required for the dry pilot lines. An OL12516AC (1/6 HP) Air Compressor is provided as standard for maintaining the air pressure in the Auxiliary Air Tank.
- The Model AMD-2 Air Maintenance Device and Model AMD-3 Nitrogen Maintenance Device, as well as the Model AMD-1 Air Maintenance Device, are offered as options when the Red-E Cabinet for Dry Pilot Actuation is ordered without a built-in automatic air supply (i.e., air compressor).
- Approvals under the name of Lansdale International
- Approvals under the name of Potter Electric Signal Company

**TABLE A**  
**PRINCIPAL COMPONENTS**  
**TECHNICAL DATA SHEETS AND LABORATORY APPROVALS**

System Type	Refer to the Following Technical Data Sheets for Complete Operation Details
Deluge, Electric Actuation	TFP1320
Deluge, Dry Pilot Actuation	TFP1315
Deluge, Wet Pilot Actuation	TFP1310

**TABLE B**  
**SYSTEM TYPES AND OPERATION**

## Care and Maintenance

Inspection, testing, and maintenance must be performed as in accordance with the requirements of the NFPA, and any impairment must be immediately corrected.

Before closing a fire protection system main control valve for maintenance work on the fire protection system that it controls, permission to shut down the affected fire protection systems must first be obtained from the proper authorities and all personnel who may be affected by this decision must be notified.

The TYCO Red-E Cabinet does not require any regularly scheduled inspection or maintenance. The riser components enclosed within the Red-E

Cabinet, however, must be maintained in accordance with their applicable technical data sheet (refer to Table A). In addition, the Control Panel and Automatic Air Supply (as applicable) components must be maintained in accordance with their applicable instructions provided with the Red-E Cabinet.

The owner is responsible for the inspection, testing, and maintenance of their fire protection system and devices in compliance with this document, as well as with the applicable standards of any authorities having jurisdiction. Contact the installing contractor or product manufacturer with any questions.

Automatic sprinkler systems are recommended to be inspected, tested, and maintained by a qualified Inspection Service in accordance with local requirements and/or national codes.

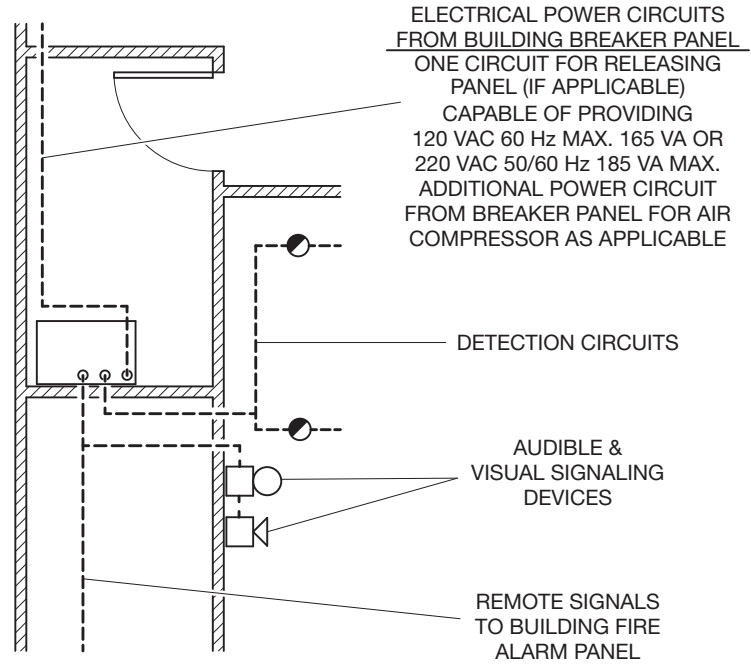

**ELECTRICAL**

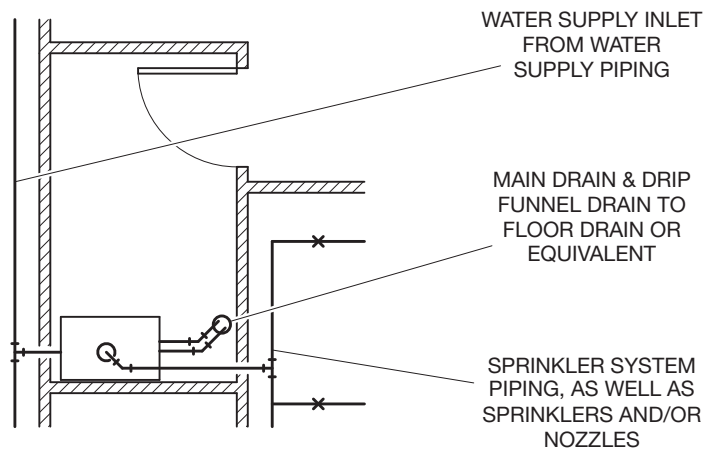

**MECHANICAL**

**FIGURE 3**  
**SYSTEM DESIGN CONSIDERATIONS**

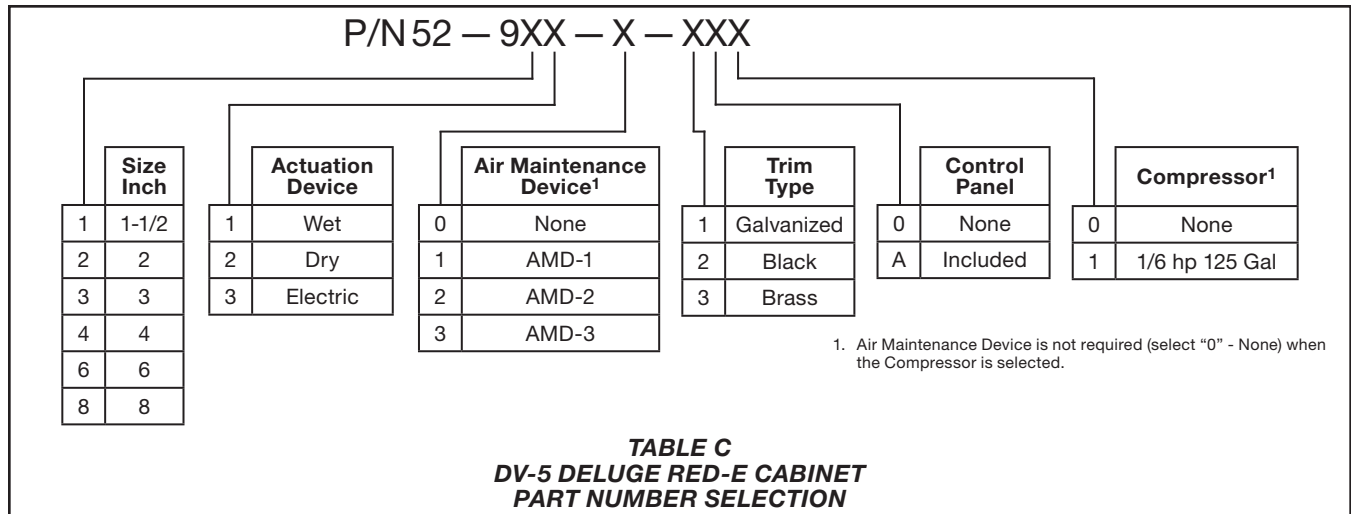

## Limited Warranty

For warranty terms and conditions, visit [www.tyco-fire.com](http://www.tyco-fire.com).

## Red-E Cabinet Technical Support

Technical support for the Red-E Cabinet is available by calling 888-572-4638 during regular business hours of 8:30-12:00 & 1:00-5:00 eastern time Monday through Friday.

The Red-E Cabinet Technical Support should be contacted for special request cabinet configurations or electrical connection/control panel programming inquiries.

An answering service will take messages outside of the regular business hours.

## Ordering Procedure

The following Part Numbers (P/N) are provided for standard cabinets with integral control panel, built-in automatic air supply (i.e., air compressor and controls for dry pilot actuation), and galvanized pipe (except supply header which is black), nipples, and fittings.

### DV-5 Red-E Cabinet with Deluge System

Specify: (size) Inch DV-5 Red-E Cabinet with (specify actuation) system riser for installation in (USA or Canada), P/N (specify per Table C)

**Note:** Dry Pilot Actuation is provided standard with a OL12516AC (1/6 HP) Air Compressor and Auxiliary Air Tank complete with one Model AMD-1 Air Maintenance Device.

### Special Order

The DV-5 Red-E Cabinet can be provided as follows as part of a special request cabinet configuration:

- without the control panel
- without built-in automatic air supply (i.e., air compressor and controls for dry pilot actuation)
- with an optional air/nitrogen maintenance device when ordered without built-in automatic air supply for dry pilot actuation
- with trim black pipe, nipples, and fittings, as may be desired for AFFF systems
- with special size air compressors for dry pilot actuation
- with 50 Hz air compressors

### Options

The DV-5 Red-E Cabinet can be provided with the following options:

- with sight flow gage (provides a visual indication of flow through the main drain)
- with extra capacity batteries (12V up to 18Ah) for longer battery time and/or systems with heavy power requirements (e.g., numerous audible signaling devices)
- with Class "A" initiating appliance circuits
- This option permits the connection of Class "A" style wiring to the initiating zones
- with Class "A" indicating appliance circuits
- This option permits the connection of Class "A" style wiring to the indicating zones
- with auxiliary relay modules to provide extra dry contacts when required; up to an 8 ARM-44 module per cabinet can be added
- with RA-4410 RC Remote Annunciator

Contact the Red-E Cabinet Technical Support group for information on special request cabinet configurations